

Received February 26, 2024, accepted March 4, 2025, publication date for online-first April 9, 2025.

Original Research Article

Discussing the Clinical Value of Full-Range Autofocus Endoscopic Cameras

Rongjiao Zhao^{1*} and Cong Yang²

¹ Hangzhou Micro Intelligent Technology Co. Ltd., Zhejiang Hangzhou, China.

² Jinan Micro Intelligent Technology Co. Ltd., Shandong Jinan, China.

* Corresponding Author Email: 378454121@qq.com

ABSTRACT

Objective: This study aims to explore the potential of full-range autofocus (FAF) technology to improve image clarity and operational ease in endoscopic procedures.

Methods: The paper analyzes the application and development of manual focus, autofocus, manual zoom, and auto zoom technologies in clinical endoscopy. The clinical value of FAF technology in endoscopy, including intelligent scene linkage and continuous optical lossless zoom, is discussed.

Results: The application of FAF technology significantly enhances medical diagnosis and treatment by providing clearer and more flexible imaging. This technology allows for seamless focusing from near to far distances, improving the accuracy and effectiveness of medical procedures.

Conclusions: The FAF technology represents a significant advancement in endoscopic technology. It not only improves diagnostic precision and treatment efficiency but also contributes to safer and more comfortable medical services, which can promote further development in the medical industry.

Keywords—Manual focus, Autofocus, Manual zoom, Auto zoom, Full-range autofocus.

Copyright © 2025. This is an open-access article distributed under the terms of the Creative Commons Attribution License (CC BY): *Creative Commons - Attribution 4.0 International - CC BY 4.0*. The use, distribution or reproduction in other forums is permitted, provided the original author(s) and the copyright owner(s) are credited and that the original publication in this journal is cited, in accordance with accepted academic practice. No use, distribution or reproduction is permitted which does not comply with these terms.

INTRODUCTION

In recent years, the medical endoscopic camera system—integration of traditional optical technology with modern computer and microelectronics technologies—has become a widely utilized medical instrument because of increased medical standards and public health awareness.¹ These systems have become increasingly common in clinical diagnosis and treatment, significantly enhancing diagnostic and therapeutic accuracy, reducing patient suffering, and accelerating recovery.

A review of related research reveals that the primary goal of endoscopic camera systems is to assist doctors in “seeing clearly” by obtaining sharp images while maintaining user-friendliness and simplicity. Thanks to advancements in focusing and zooming technologies, endoscopic cameras have evolved from “manual focus to autofocus, manual zoom to auto zoom, and then to full-range autofocus (FAF),” thus greatly facilitating clinical procedures, ensuring the clear vision, reducing surgical risks, improving surgery success proportions, and enhancing the functionality and application experience of endoscopes.

This process not only marks technological advancement but also reflects the broader trend in medical equipment development toward efficiency, precision, and ease of use. The primary objective of this study is to analyze the application of autofocus and zoom technologies in endoscopes, and discuss their positive impacts on medical diagnosis and treatment. Furthermore, we explore the potential future influence of these technologies on the development of endoscopic technology.

TECHNOLOGICAL EVOLUTION IN ENDOSCOPIC FOCUSING

Clinical Requirements for Imaging Precision

Endoscopic surgery is intricate and complex, requiring clear imaging to present the details of the observation area to improve the diagnosis proportion of lesions (especially early and subtle lesions), thereby facilitating the doctor’s surgical intervention. For example, when doctors perform gastrointestinal surgery, to prevent unnecessary damage caused by intestinal adhesion, clear images of the lesion are required. This clarity aids doctors in observation and

operation, reducing the risks associated with the blindness of traditional surgery, and minimizing organ damage and functional interference.

Manual Focus

In order to ensure a clear field of view in usage scenarios, medical endoscopic cameras initially introduced manual focus technology. This technology requires the operator to rotate manually the focusing ring based on visual judgment. The focusing effect heavily depends on the operator’s subjective judgment and precise adjustment, demanding a high level of skill from the operator. In practice, human errors are inevitable, making it difficult to guarantee clarity, and the operation process generally takes about 3 seconds or even more.

Autofocus

In medical scenarios, doctors often need to obtain the clearest images as quickly as possible. Therefore, with the development of electronic technology, autofocus technology has been introduced into endoscopic cameras. This technology uses sensors to detect the distance between the target scene and the lens, automatically adjusting the focus. Operators only need to click a button on the camera, and the lens will automatically adjust to the clearest image based on image clarity and the theoretical focus position, significantly simplifying the use of endoscopes and making them highly suitable for medical applications.

The principle of autofocus is as follows: Optical signals received by the integrated optical lens are transmitted to the image sensor module, where the image sensor inside converts the optical signals into electrical signals that are then sent to the camera’s processor. The processor runs an autofocus algorithm that controls an internal motor to execute the focusing operation.

The autofocus algorithm first filters the input image at the current motor position to reduce noise interference, and then enhances brightness through gamma correction. It then segments the image and calculates high-frequency information to characterize image clarity, adjusting the motor position based on the rate of clarity change. As the motor position changes, the mechanical distance matched by the optical lens group changes, thereby achieving the

focusing effect. This cycle continues until the clarity is maximized, at which point focusing is complete. An illustrative diagram of the autofocus algorithm is shown in Figure 1.

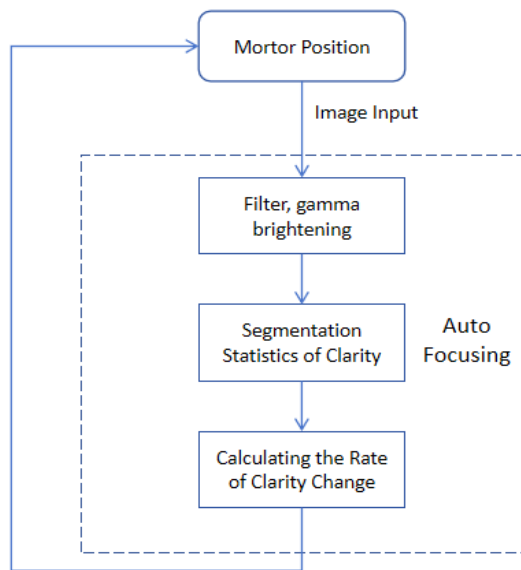

FIGURE 1. Schematic diagram of the autofocus algorithm start-up.

Zoom Technology: From Mechanical to Liquid Lens Solutions

Constraints of Fixed Focal Length

The difference between “fixed focus” and “zoom” lies in the variability of the focal length. Fixed focus means the focal length is fixed, and clear focus can only be achieved at a certain distance; zoom means the focal length is adjustable, and the magnification of the zoom lens can vary.² Initially, most endoscopic cameras adopted a “fixed focus” design.

Owing to the larger focal length resulting in a smaller field of view, different fixed-focus lenses typically have their respective usage scenarios. For example, ear, nose, and throat (ENT) and gynecology endoscopes commonly use a focal length of F14, as doctors prefer to observe smaller and more comprehensive images; urology often uses a focal length of F22; images from a focal length of F28 are more popular in thoracic surgery and some laparoscopic surgeries; while a focal length of F32 is the most common one in major abdominal surgeries. Therefore, although the advent of autofocus technology can provide doctors with a convenient and rapid focusing

experience, fixed-focus cameras can only focus at a specific distance and cannot be adjusted. Clinically, it is still necessary to equip multiple fixed-focus mounts, such as F14, F22, F28, F32, etc., to meet the needs of different departments for different depths and field sizes, limiting the application of endoscopes in complex surgeries.

Zoom has always been a clinical challenge.³ Endoscopic zoom lenses were developed to address this issue. Zoom lenses can change the focal length by moving the internal optical components, thus changing the field of view through “zooming”. A single “zoom” lens equates to an integration of multiple “fixed-focus” lenses. When using a zoom lens, there’s no need to switch between different fixed-focus lenses, as the clearest image is obtained at any position within a certain distance by operating the zoom. Now the zoom technology is divided into manual zoom and auto zoom.

Manual Zoom

Manual zoom is primarily achieved through detachable optical zoom adapters. By manually adjusting the optical adapter, the internal optical lens group is altered, achieving zoom.⁴ While manual zoom cameras are more flexible than fixed-focus cameras, they still fall short in meeting the fast-paced and high-precision requirements of medical environments.

Auto Zoom

Owing to the precision required in surgical interventions, auto zoom systems must be miniaturized,⁵ structurally simple, and compact, and must meet image quality requirements. With the continuous development of camera technology, particularly in liquid lenses, auto zoom endoscopic cameras have started to emerge. Liquid lenses use specific control methods to adjust the refractive index or shape of the lens, offering a novel approach to zooming. These lenses are characterized by fast zoom response times, low power consumption, and noise-free operation, which distinguish them from traditional lenses.² They offer the benefits of low manufacturing costs, simple structure, and easier miniaturization.⁶

The principle of auto zoom involves electrowetting, which manipulates the liquid’s wetting properties via an electric field, thereby altering its shape and curvature. A liquid lens contains two immiscible liquids—nonconductive

oil and a water solution—separated by an interface. By applying voltage across the interface, the lens curvature can change in tens of milliseconds, altering the focal length. Increased voltage increases lens curvature and optical power.⁷ Figures 2 and 3 show the liquid lens in de-energized and energized states, respectively. Liquid lenses, particularly those utilizing electrowetting, offer a tunable focal length by adjusting the curvature of a liquid surface.⁸ These lenses have been successfully incorporated into zoom systems, such as the design by Park and Park,⁹ which utilized liquid lenses to achieve variable focal lengths for compact mobile cameras. Moreover, recent developments have seen the combination of liquid lenses with other optical elements to enhance zoom capabilities without the need for moving parts, as demonstrated in the continuous zoom systems for telescopes by Jiang et al.¹⁰ Additionally, stabilizing mechanisms for liquid lens-based zoom systems have been explored to improve precision and reliability, as discussed in the four-group zoom system proposed by Li et al.¹¹ Figure 4 shows the step-by-step workflow of FAF technology, from image capture to focus adjustment, and finally to image clarity feedback.

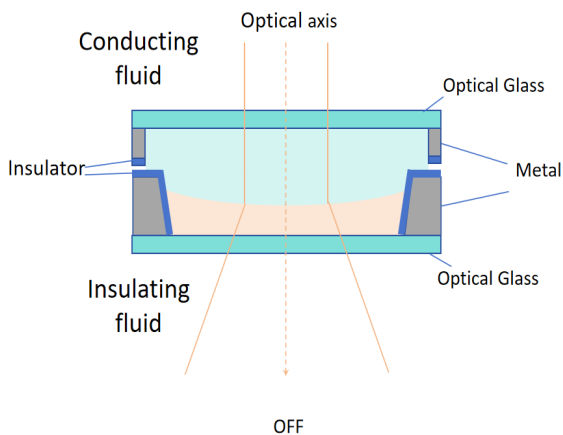

FIGURE 2. Schematic diagram of liquid lens in de-energized state.

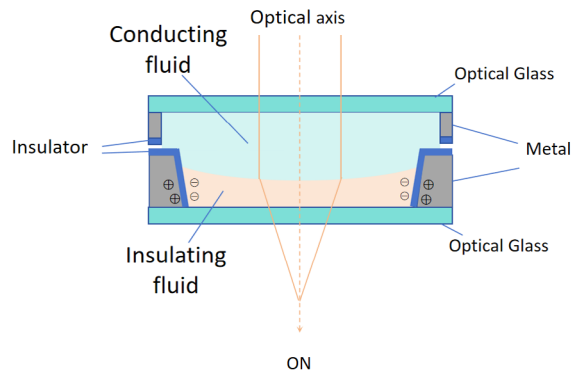

FIGURE 3. Schematic diagram of liquid lens in energized state.

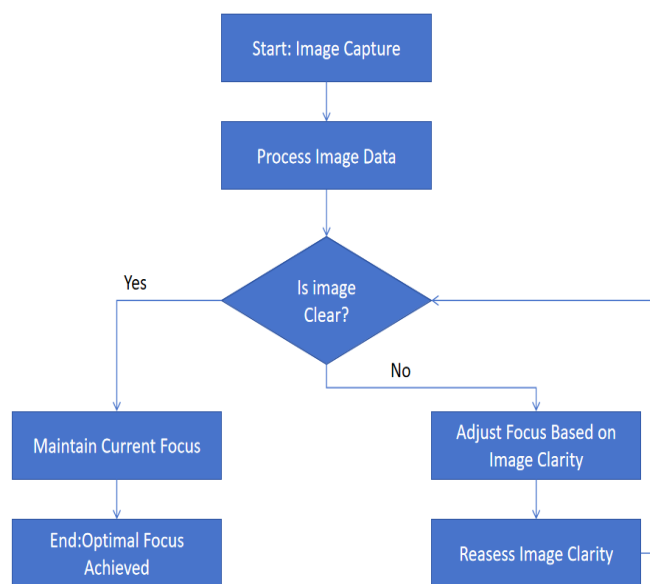

FIGURE 4. Schematic diagram of FAF workflow.

THE APPLICATION OF FULL-RANGE AUTOFOCUS TECHNOLOGY IN CLINICAL PRACTICE

The FAF technology, which integrates the advantages of both autofocus and zoom, has significantly enhanced the

field of medical endoscopy, particularly in clinical diagnosis and treatment. This technology enables continuous focusing from near to far distances, significantly improving the imaging quality and flexibility of endoscopes, providing doctors with clearer and more comprehensive views, and profoundly impacting disease diagnosis and treatment.

First, the technology enables continuous zoom across multiple focal lengths, from F14 to F32, facilitating one-click switching between distant, medium, and close-up views. The camera system can achieve intelligent scene linkage; by setting focal lengths for different surgical scenarios in the endoscope's control system, the camera automatically adjusts to the most appropriate and effective focal length for the scenario. A single FAF camera can seamlessly switch between focal lengths of F14 and F32, accommodating the usage habits of doctors across various departments.

Second, traditional endoscopy faced limitations in deep scene imaging, restricting doctors' ability to observe lesion areas. The FAF-equipped endoscopes achieve optical, lossless continuous zoom, allowing for undistorted magnification and direct observation of suspicious areas without losing detail. Compared to traditional digital magnification, this method offers superior magnification, lossless images, and reduced noise, effectively resolving issues with "extremely small" lesions, such as tiny blood vessels and outlines, improving visual precision. This is particularly crucial for early detection, such as during gastrointestinal examinations, where FAF can enhance the detection of minor abnormalities in the mucosa, increasing early cancer detection rates and the identification of other serious conditions.

Moreover, the FAF technology can be combined with auto zoom to achieve one-click autofocus. This ensures precise focusing with minimal margin for error, faster and more accurately than traditional manual focus methods. This enhances surgical efficiency and reduces the risks associated with inaccurate focusing, thus making surgeries more precise and improving the clinical experience.

Additionally, the application of FAF technology greatly improves patient comfort. In traditional procedures, frequent adjustments to the endoscope's position to achieve clarity can cause patient discomfort. However, FAF reduces the

need for frequent positional adjustments, decreasing patient discomfort and enhancing patient satisfaction.

Finally, this technology offers greater opportunities for medical research and education. High-definition, full-range images allow researchers to closely observe and record disease progression, which is essential for studying mechanisms of medical diseases and developing new treatments. These high-quality images also serve as educational resources, assisting medical students and young doctors in understanding the characteristics of various diseases.

CONCLUSION

Considering the current research and development trends in endoscopic devices,¹ there is a growing preference for miniaturization to enhance the safety and comfort of endoscopic procedures.⁸ Furthermore, with the future deep integration of artificial intelligence (AI)¹² and machine learning (ML) technologies, the autofocus and zoom systems of medical endoscopic cameras are expected to achieve greater levels of intelligence and automation. This could include real-time image analysis, predictive focusing, and automatic adjustment of parameters to meet the constantly changing requirements of the surgical field. These innovations will continue to improve image quality during procedures, providing doctors with more intuitive and effective tools for surgery.

AUTHOR CONTRIBUTIONS

Conceptualization, R.J.Z.; Methodology, R.J.Z.; Writing–Original Draft Preparation, R.J.Z.; Writing–Review & Editing, R.J.Z. and C.Y.; Project Administration, R.J.Z.

ACKNOWLEDGMENTS

The research team acknowledges the optical engineer Mr. Guo for his advice and assistance in the construction of the experimental platform for valuable input on developing this paper.

FUNDING

This research received no external funding.

DATA AVAILABILITY STATEMENT

Not applicable.

CONFLICTS OF INTEREST

The authors declare they have no competing interests.

ETHICS APPROVAL AND CONSENT TO PARTICIPATE

Not applicable.

CONSENT FOR PUBLICATION

Not applicable.

FURTHER DISCLOSURE

Not applicable.

REFERENCES

1. Boese A., Wex C., Croner R., et al. Endoscopic Imaging Technology Today. *Diagnostics*. 2022;12(5):1262. <https://doi.org/10.3390/diagnostics12051262>.
2. Zhang, Y., Zhang, X., Shi, G.W., et al. Applications of liquid lenses in zoom systems. *China Optics*. 2013;6(1):47. <https://doi.org/10.3788/co.20130601.0046>.
3. Lee, S.W., Choi, M.C., Lee, E.S., et al. Zoom lens design using liquid lens for laparoscope. *Opt Express*. 2013;21:1751–1761. <https://doi.org/10.1364/OE.21.001751>.
4. Luo, X.F., Shi, Y., Guo, F., et al. Design of a large imaging plane wide-band zoom adapter optical system for endoscopes. *Opt Express*. 2025;33:2809–2823. <https://doi.org/10.1364/OE.550768>.
5. Du, L.H., Wang, L.Q., Ye, B., et al. Portable electronic endoscopic imaging system. *Proc. SPIE 7850, Optoelectronic Imaging and Multimedia Technology*. 2010;785003. Photonics Asia 2010, 2010, Beijing, China. <https://doi.org/10.1117/12.869795>.
6. Liu, H.B., Hu, Y., Li, Y.Z., et al. Review of Current Status and Development of Liquid Lens. *Laser & Optoelectronics Progress*. 2024; 61(9): 0900005. <https://doi.org/10.3788/LOP231170>.
7. Zhang, W., Jin, Y.T., Guo, X., et al. Design of an autofocus capsule endoscope system and the corresponding 3D reconstruction algorithm. *J Opt Soc Am A*. 2016;33:1970–1977. <https://doi.org/10.1364/JOSAA.33.001970>.
8. Mishra, K., van den Ende, D., Mugele, F. Recent developments in optofluidic lens technology. *Micromachines*. 2016;7:102. <https://doi.org/10.3390/mi7060102>.
9. Park, S-C and Park, J. Zoom lens design for a slim mobile camera using liquid lens. *J Korean Phys Soc (JKPS)*. 2009;54:2274–2281. <https://doi.org/10.3938/jkps.54.2274>.
10. Jiang, Z., Zheng, Y., Wang, X., et al. Continuous optical zoom telescopic system based on liquid lenses. *Optics Express*. 2024;32:15269–15283. <https://doi.org/10.1364/OE.520475>.
11. Li, H., Cheng, X.M., Hao, Q. An electrically tunable zoom system using liquid lenses. *Sensors*. 2015;16:45. <https://doi.org/10.3390/s16010045>.
12. Bae J.K., Vavilin A., You J.S., et al. Smartphone-Based Endoscope System for Advanced Point-of-Care Diagnostics: Feasibility Study. *JMIR Mhealth Uhealth*. 2017;5(7):e99. <https://doi.org/10.2196/mhealth.7232>.