

Received May 21, 2020, accepted June 25, 2020, date of publication July 6, 2020

Redesigning protective gear for health workers during the COVID-19 pandemic: leveling up the “aerosol box”

By R. Moreno¹, E. Pedraza², F. Morales, R. Mijares², R. Boccardo² and M.A. García²

¹Hospital de Clinicas Caracas (HCC) / Clinica Santa Paula (CSP), Caracas-Venezuela.

²Universidad Simon Bolivar (USB), Caracas-Venezuela.

ABSTRACT

Background and Objective: During the last decade, Venezuela has suffered several crises concerning its health, socio-economic, and political institutions. While having a minimum wage of roughly \$2.32 US dollars per month, and a precarious quality and coverage of public services (such as water, public transportation, electricity, and Internet services), the COVID-19 virus struck the nation. This pathology became a pandemic quickly since its transmission occurs mainly through contact with the secretions of infected patients or with contaminated surfaces. Health workers face a higher risk of infection than the rest of the population. For this reason, the objective of this work is to reduce the threat that medical personnel face while working with COVID-19 patients and redesigning the original “spray box,” to avoid further deterioration of the health institutions. The cooperation and support of the Universidad Simon Bolivar (USB) and the Hospital de Clinicas Caracas (HCC), as well as the job of the manufacturer companies, was exceptional for accomplishing this work.

Materials and Methods: To develop the prototype, the following phases were carried out: (a) A sketch was created; (b) A 3-D CD model was created; (c) The prototype was manufactured; (d) The prototype was improved; and (e) The effectiveness and safety tests were carried out.

Results: The research team produced protective gear for the safety and health of medical personnel when attending patients with COVID-19 to help limit the spread of the virus. This instrument was called “Cube de Vie” (CubeDV).

Conclusions: The work demonstrates that disregarding the struggling circumstances Venezuela faces daily, it was possible to solve a problem that threatened public health globally, to fight the serious COVID-19 pandemic. CubeDV was a result in a time of crisis and added another tool in the fight against the virus. This gear is just one example of our longing to win this fight and we hope it will represent significant help for people involved in fighting against this crisis.

Keywords – SARS-CoV-2, COVID-19, protection, personnel, health, CubeDV, box, aerosol, workers, protective gear, pandemic, infection risk.

Copyright © 2021. This is an open-access article distributed under the terms of the Creative Commons Attribution License (CC BY): *Creative Commons - Attribution 4.0 International - CC BY 4.0*. The use, distribution or reproduction in other forums is permitted, provided the original author(s) and the copyright owner(s) are credited and that the original publication in this journal is cited, in accordance with accepted academic practice. No use, distribution or reproduction is permitted which does not comply with these terms.

INTRODUCTION

The United Nations (UN) and international health agencies have indicated that Venezuela's health crisis is causing an increase in infectious diseases, and the resurgence of others that were once considered eradicated, such as malaria or tuberculosis. The World Health Organization (WHO) considers that the political and socio-economic

situations in Venezuela are responsible for the collapse of the healthcare system since those conditions have caused a severe scarcity of medical supplies, the closure of many clinics and hospitals, and a significant decrease of medical personnel who have emigrated from the country.

Since February 23, 2020, the closure of Wuhan in China alarmed the world population with the presence

of a new coronavirus (SARS-CoV-2), which causes the COVID-19 disease. This virus managed to spread globally in a considerably short time becoming a pandemic. Globally, public health has been facing significant challenges in consequence of this situation,¹ to this date (04-30-2020), the WHO has confirmed 3,090,445 cases and 217,769 deaths worldwide.²

The transmission of COVID-19 occurs mainly through droplets which are responsible for spreading the virus when they come in contact with healthy individuals, whether directly or indirectly through contaminated surfaces. Coughs, sneezes, and some medical airway management procedures can also produce aerosols made up of smaller airborne particles (droplets), which may contain this virus. These airborne particles can travel long distances and be inhaled, increasing the risk of transmission of COVID-19.¹⁻⁵

During the SARS-CoV outbreak in Canada (2002), half of all SARS-CoV cases were nosocomially transmitted to healthcare workers. During these high-demand times, the available human resources to attend to patients may decrease significantly, especially in countries with struggling healthcare institutions as considerable personnel have been subjected to quarantine and isolation measures to try to prevent further transmission of the virus. In healthcare institutions, the virus is widely distributed in the air and on the surfaces of objects (for example floors, garbage cans, handrails for sickbeds, and computer mouse devices). This can include general rooms, intensive care units,⁶ and cardiac laboratory rooms.⁷

In this regard, healthcare workers are threatened with an increased risk of infection, while managing COVID-19 positive patients or by performing procedures that may generate aerosolized saliva particles, such as mechanical ventilation, misting medication, non-invasive ventilation, manual ventilation, tracheal intubation and aspiration, secretion aspiration, bronchoscopy, endoscopy, bronchoalveolar lavage, surgical tracheostomy, or cardiopulmonary resuscitation. Several guidelines and recommendations have been published and introduced to reduce these risks; however, the cases of infections and deaths in health professionals due to COVID-19 are still increasing in institutions with patients with serious complications.⁸

Recently, Robert Canelli et al⁹, published a study in which they tested the effectiveness of a barrier that they

called an "aerosol box", which consisted of a transparent plastic that could cover the head of a patient, and incorporated two circular ports to perform medical airway procedures. To demonstrate the effectiveness of the box, they simulated a "strong cough" with a small latex balloon containing 10 mL of fluorescent dye in the hypopharynx of an anatomical model. The explosion of this balloon produced an expansion of dyed particles in the area. They repeated the experiment with and without the aerosol box and illuminated the scene with ultraviolet light to visualize the spread of the dye. With the use of the aerosol box, the simulated cough was only able to "contaminate" the internal surface of the box, and the covered arms and gloves of the worker performing the laryngoscopy. However, with further examination, they concluded that the simulation method was not valid enough to prove an accurate direction of the liquid, its speed, turbulence, or particle size distribution, as it would happen with real coughs. Taking this background into account, this "aerosol box" was redesigned to increase the protection of healthcare workers performing high-risk procedures on COVID-19 patients.⁹

MATERIAL AND METHODS

The following phases were carried out: (a) A sketch was created; (b) A 3-D CD model was created; (c) The prototype was manufactured; (d) The prototype was improved; and (e) The effectiveness and safety tests were carried out.

RESULTS

A Sketch was Created

Analyzing the original design of the aerosol box, with the experience of medical anesthesiologists, and with the support of the multidisciplinary team, the medical device was redesigned with two specific criteria: safety and effectiveness.

To achieve those criteria, the following improvements were made:

- An inclined front panel that limits the particles to the distal plane of the patient, and that allows a complete visualization of the procedure to be performed on the patient (Figure 1 in annexes).

- More length to cover the patient, since the redesigned box measures approximately 60 cm (23.6 inches) from the patient's head to the upper chest (Figure 1).
- The incorporation of a distal flange that reduces the possibility of particle expansion outside the box (Figure 2).
- The addition of two lateral closing holes to reduce the risk of infection of the auxiliary personnel in the following procedures: intubation, Sellick's maneuvers, BURP, cuff inflation, or endotracheal tube fixation.



FIGURE 1. Inclined front panel and CubeDV extension.

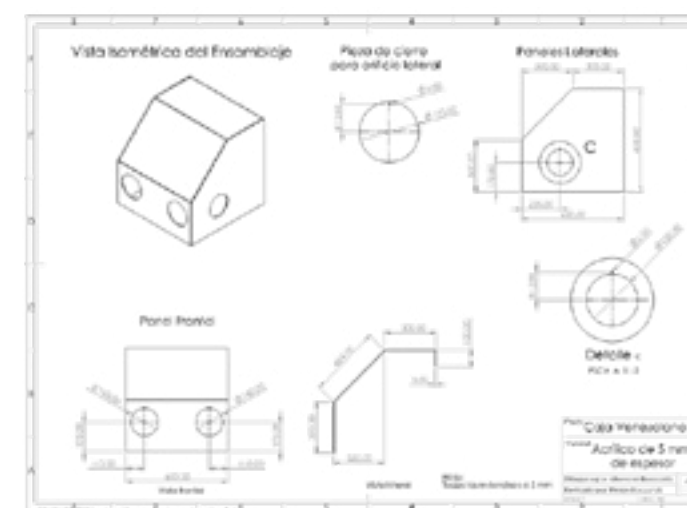

FIGURE 2. CubeDV sketches of the design.

A 3-D model Was Created

The sketch is represented in a three-dimensional shape and was analyzed by specialists. This new gear was named "Cube de Vie" (CubeDV). After some corrections, we moved on to the next step.

The Prototype Was Manufactured

CubeDV is made entirely of 3-mm polymethylmethacrylate (PMMA). In order to keep costs as low as possible, the team aimed for the use of the smallest possible caliber of sheets that could provide stability. To shape the box, the surface on which it is supported was heated. Afterwards, gutters were drilled at the joint points of the three main pieces of the box, this allowed the sheets to fit into a channel that also added support and stability to the entire system. Additionally, at these joint points, chloroform was used as a chemical weld, since it dissolves a small layer of the plastic, to allow the pieces to combine and harden.

The Prototype was Improved

After some stability tests, it was decided to make a thicker prototype, using 5-mm PMMA. The material used on the CubeDV, PMMA, is probably the most transparent plastic material and is also resistant to degradation by UV radiation. PMMA is not heavy due to its low density (1190 kg/m³), which is less than half that of glass making it is easy to transport. It is also 15 times more resistant than ordinary non-tempered glass of the same thickness. As well, PMMA is washable and not affected by detergents and commercial solutions commonly used in hospitals for cleaning and disinfecting potentially infected medical equipment.

The CubeDV is an economical, reusable, easy to transport tool, with the ideal dimensions to carry out procedures with great comfort and protection. To comply with Venezuelan national regulations, quality certification of the medical device was necessary, to demonstrate its effectiveness and safety.

The Effectiveness and Safety Tests were Carried Out

To simulate the dispersion of the virus, a test was performed in the operating room area of the Hospital de Clinicas Caracas (HCC) with a volunteer as a patient, who simulated sneezing with a fluorescent liquid aerosol device (Figure 3), which he squeezed at mouth level at

the time of intubation. The test was carried out in two stages, with and without the CubeDV. In both cases, the expansion of the aerosol particles was recorded with the addition of ultraviolet light through photographs, filming, and testimony of the medical team in the operating room. In the first step of the investigation (without CubeDV) the results showed that the distribution of the fluorescent aerosol particles from the position of the patient (where the spray was triggered), was: 1.2 meters (47.2 inches) away in both right and left sides, 1 meter (39.4 inches) in the air, the superior plane of the patient (Figure 4), 1.1 meters (43.3 inches) in the coronal plane and 1 meter (39.4 inches) in the distal plane. Moreover, there was an evident presence of particles in the facial protection masks of the operator (Figure 5). Subsequently, the second step of the investigation was carried out with the CubeDV, reporting the distribution of the aerosol particles only on the internal part of the box (Figure 6) and on the covered hands and forearms of the operator (Figure 7). The use of CubeDV was also tested in other medical procedures such as: bronchoscopy, upper digestive endoscopy, and induction of inhalation anesthesia in pediatric patients.



FIGURE 3. Inclined front panel and CubeDV extension.

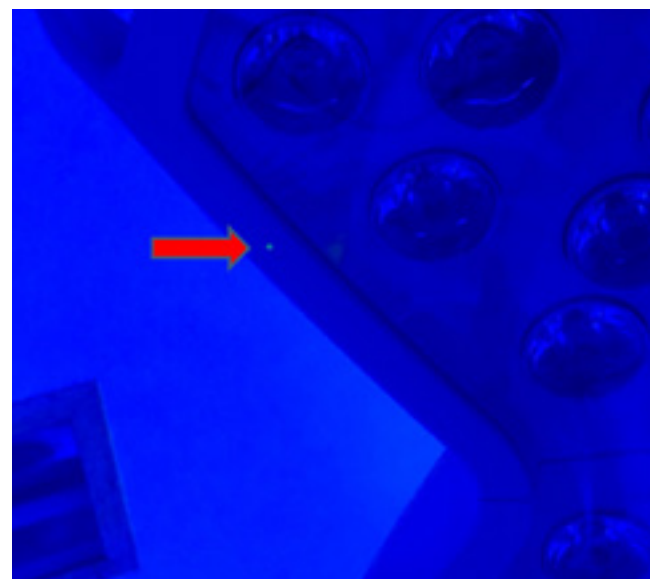

FIGURE 4. Upper extension of the fluorescent ink to the surgical lamp.

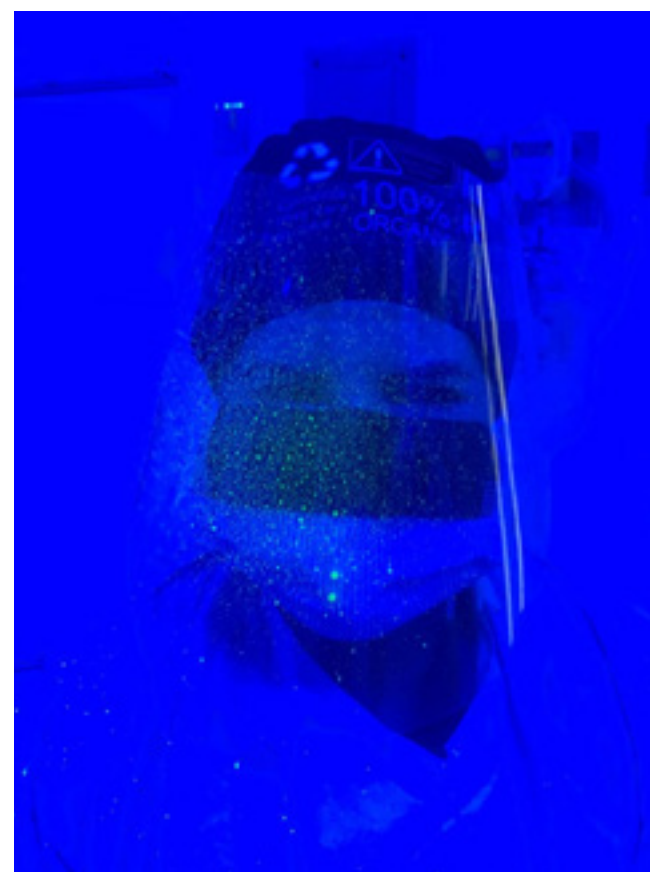

FIGURE 5. IFluorescent ink spread to operator and assistant facial protection.



FIGURE 6. Containment of the fluorescent ink inside the CubeDV.



FIGURE 7. Fluorescent ink spread limited to operator's forearms with use of CubeDV.

The Use of the CubeDV

From the tests carried out on the CubeDV to prove its effectiveness, the following results were obtained: (a) The sloped front panel allows an important improvement of the visibility of the patient; (b) The CubeDV's improved length played an important role in protecting health workers during procedures with high risk of infection; (c) The distal flange decreases the possibility of particle expansion outside the box. The tests showed that the CubeDV contained both the droplets and the large diameter drops, thus avoiding dispersion and contamination of the area; (d) The lateral closing holes reduced the risk of exposure of assisting personnel during different procedures.

CONCLUSIONS

This work demonstrates that in spite of the the struggling circumstances Venezuela faces daily, it is possible to solve a problem that threatens global public health and to fight the serious COVID-19 pandemic.

Taking into consideration the length of the box, the improved panel, and its material, it is possible to conclude that the team of HCC and USB obtained an effective result when redesigning the aerosol box. Our analysis and tests suggested that the CubeDV may play an exceptional job protecting the health workers while attending to infected patients.

CubeDV is a result in a time of crisis and another tool in our fight against the COVID-19. This protective gear is just one materialized example of our efforts to win this fight, and we hope, and to provide significant help in this crisis.

ACKNOWLEDGMENTS

To the group of anesthesiologists of the Hospital de Clinicas Caracas, who supported the financing of the prototype and facilitated their working hours to carry the tests out.

REFERENCES

1. Huang C, Wang Y, Li X, et al. Clinical features of patients infected with 2019 novel coronavirus in Wuhan, China. Lancet 2020 Feb 15;395(10223):497–506.

2. OMS. Coronavirus disease 2019 (COVID-19) Situation Report – 72. OMS. April 2020. Available at: <https://www.who.int/es/home>
3. Li Q, Guan X, Wu P, et al. Early transmission dynamics in Wuhan, China, of novel coronavirus-infected pneumonia. *N Engl J Med* 2020 Mar 26;382(13):1199–207.
4. Chan JF, Yuan S, Kok KH, et al. A familial cluster of pneumonia associated with the 2019 novel coronavirus indicating person-to-person transmission: a study of a family cluster. *Lancet* 2020 Feb 15;395(10223):514–23.
5. Brewster DJ, Chrimes NC, Thy BT Do, et al. Consensus statement: Safe Airway Society principles of airway management and tracheal intubation specific to the COVID-19 adult patient group. *Med J Austr* March 2020. Available at: <https://www.mja.com.au/journal/2020/consensus-statement-safe-airway-society-principles-airway-management-and-tracheal>
6. Guo ZD, Wang ZY, Zhang SF, et al. Aerosol and surface distribution of severe acute respiratory syndrome coronavirus 2 in hospital wards, Wuhan, China, 2020. *Emerg Infect Dis* 2020 Apr 10;26.
7. Romaguera R, et al. Consideraciones sobre el abordaje invasivo de la cardiopatía isquémica y estructural durante el brote de coronavirus COVID-19. *REC Interv Cardiol*. 2020. <https://doi.org/10.24875/RECIC.M20000119>.
8. Gobierno de España. Manejo clínico de pacientes con enfermedad por el nuevo coronavirus (COVID-19) Available at: <https://www.sedar.es/images/site/NOTICIAS/coronavirus/Protocolo-manejo-clinico-COVID-19.pdf>
9. Canelli R, Connor C, González M, et al. Barrier enclosure during endotracheal intubation. *N Engl J Med* 2020; 382:1957–58.
10. Mijares R, Utrera N, Sierra Z, et al. Quality certification of medical devices in Venezuela: Process Developed by Simón Bolívar University, Caracas-Venezuela. *Global Clin*